

F328

Low Force Universal Loadcell

Standard Ranges 10, 20, 50, 100, 200 and 500N (1 to 50kg)

- ◆ Low force loadcell
- ◆ Totally passive design
- ◆ Wheatstone bridge device
- ◆ Foil strain gauges
- ◆ High thermal stability
- ◆ Low power consumption
- ◆ Extraneous load rejection for vectors up to 30° off axis



The F328 is an axial low force universal loadcell with quantified extraneous load and moment rejection.

Its high resistance 5000Ω strain gauge bridge makes this loadcell ideal for battery powered applications such as a laptop computer with a DSC USB loadcell digitiser or a hand held TR150 loadmeter.

The strain system exploits a laminated structure producing excellent extraneous force and moment rejection together with minimal translational deflection. Novatech have quantified the errors present with combinations of side load and associated induced moments in Engineering Application Sheet E034.

We are happy to design variants of this loadcell to meet your specific requirements.

Details of our other loadcell families can be found in the Loadcell Specifier Guide. If you require a copy please contact our sales department or look on our web site at www.novatechloadcells.co.uk.

Ordering Codes:		See the loadcell ordering code sheet for more details. Add range in the required units.	
F328TF00B0	Tension, unrationalised	F328TF00BN	Tension, rationalised
F328DF00B0	Compression, unrationalised	F328DF00BN	Compression, rationalised
F328UF00B0	Bi-directional, unrationalised	F328UF00BN	Bi-directional, rationalised

F328 Specification

Parameter	Value	Unit
Non-linearity - Terminal	±0.15	% RL
Hysteresis	±0.15	% RL
Repeatability	±0.05	% RL
Rated output - Nominal	1.2	mV/V
Rated output - Rationalised	1.0	mV/V
Rationalisation tolerance	0.5	%RL
Zero load output	±10	% RL
Temperature effect on rated output per °C	0.005	%AL
Temperature effect on zero load output per °C	0.01	%RL
Temperature range - Compensated	-10 to +50	°C
Temperature range - Safe	-10 to +80	°C
Excitation voltage - Recommended	10	V
Excitation voltage - Maximum	20	V
Bridge resistance	5000	Ω
Insulation resistance - Minimum at 50Vdc	500	MΩ
Overload - Safe	50	% RL
Overload - Ultimate	100	% RL
Weight – Nominal (excluding cable)	9 to 29	g

The ranges up to 50N are manufactured in aluminium; ranges above 50N are manufactured in stainless steel.
This loadcell has compensation components housed in a capsule located in the loadcell cable 100mm from the free end. Capsule dimensions are Ø10mm by 57mm.

Structural stiffness - Nominal					
Range (N)	Stiffness (N/m)	Range (N)	Stiffness (N/m)	Range (N)	Stiffness (N/m)
10	5.3×10^5	100	2.2×10^6		
20	1.0×10^6	200	4.3×10^6		
50	2.6×10^6	500	1.1×10^7		

Notes

1. AL = Applied load.
2. RL = Rated load.
3. Temperature coefficients apply over the compensated range.

Connections

The loadcell is fitted with 2 metres of PVC insulated 4 core screened cable type 7-1-4C.

Excitation + = Red

Signal + = Yellow

Screen = Orange

Excitation - = Blue

Signal - = Green

The screen is not connected to the loadcell body.

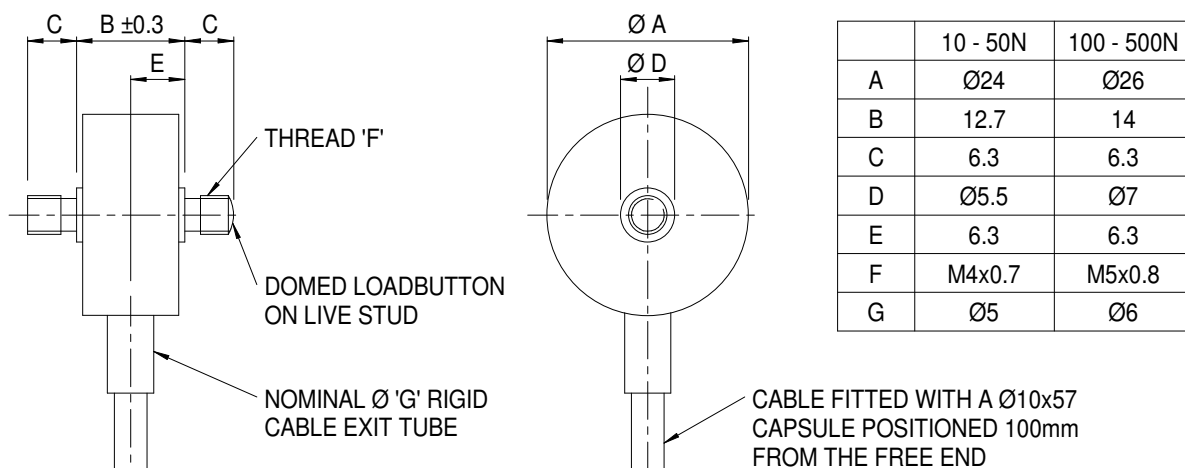

Novatech reserves the right to vary the foregoing details without prior notice

01/2010

NOVATECH MEASUREMENTS LTD

83 CASTLEHAM ROAD, ST LEONARDS ON SEA, EAST SUSSEX, TN38 9NT, ENGLAND

Tel: 01424 852744

email: info@novatechloadcells.co.uk

Fax: 01424 853002

www.novatechloadcells.co.uk